

# EchoRange™ Smart™ Sensors Available in Single and Dual Frequency Models

## Best Valued Portable Depth Sensors for Hydrographic Surveying

### 200 kHz and 30/200 kHz Transducers with Embedded Signal Processing

Accurate measurement of water depth from 0.4 m to 200 m

- Hydrographic surveying of harbors, waterways and coastal water areas
- Dredging management operations
- Mobile field work

### What makes Airmar sensors smarter than the rest?

Airmar's patented Smart™ sensors feature embedded microelectronics that process depth and temperature inside the sensor that can be instantly displayed on any device that accepts NMEA data. EchoRange™ transfers NMEA 0183 data in real time to a computer via RS422.

### Customizable Operation

The EchoRange™ can be successfully operated in most open water applications using the factory default settings. In other applications (such as when deployed in enclosures, or when using multiple devices, or when using with battery power) the user can optimize the EchoRange™ performance by changing one or some combination of the factory default settings.



When performance matters most we've got you covered.



# EchoRange™ Smart™ Sensors

## SS510 Single Frequency



## M195 Dual Frequency



\*Echo envelope developer option is also available to OEM's

### SS510 HOUSING DIMENSIONS

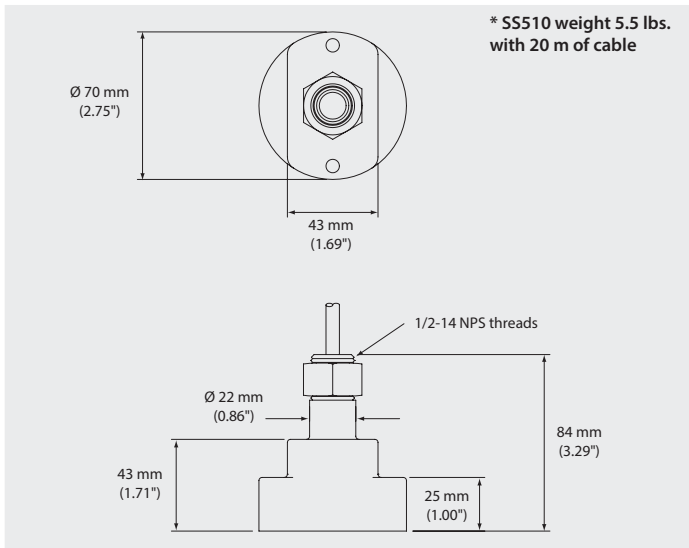

### M195 HOUSING DIMENSIONS

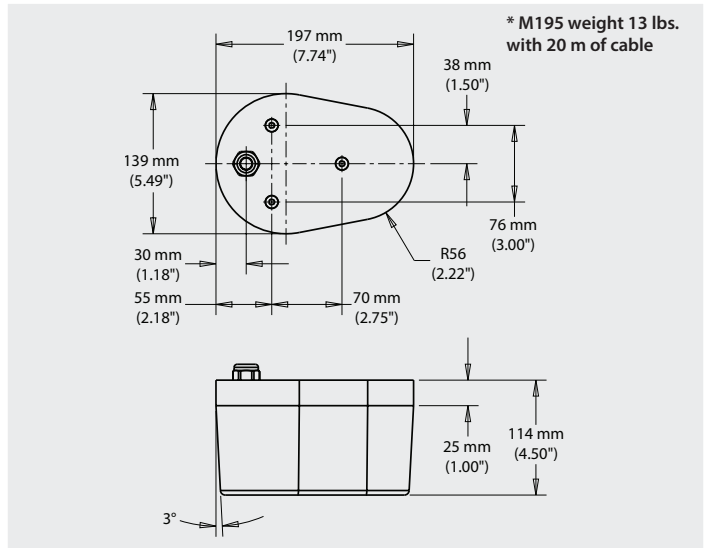

Frequencies	Configuration	Beamwidth (@-3 dB)
200 kHz		9°

Frequencies	Configuration	Beamwidth (@-3 dB)
30 kHz		26°
200 kHz		9°

### OPERATIONAL CURRENT DRAW

9 V peak (during ping) input current: 1 A  
 9 V average input current: 150 mA  
 12 V peak (during ping) input current: 1 A  
 12 V average input current: 150 mA  
 24 V peak (during ping) input current: 600 mA  
 24 V average input current: 100 mA  
 40 V peak (during ping) input current: 400 mA  
 40 V average input current: 50 mA

### OPERATIONAL CURRENT DRAW

9 V peak (during ping) input current: 2 A  
 9 V average input current: 400 mA  
 12 V peak (during ping) input current: 1.7 A  
 12 V average input current: 300 mA  
 24 V peak (during ping) input current: 800 mA  
 24 V average input current: 200 mA  
 40 V peak (during ping) input current: 600 mA  
 40 V average input current: 150 mA

### TRANSDUCER CONFIGURATIONS

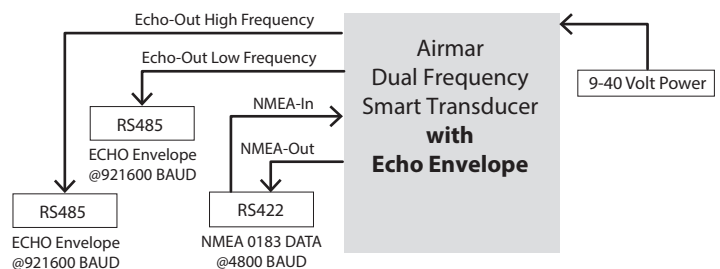
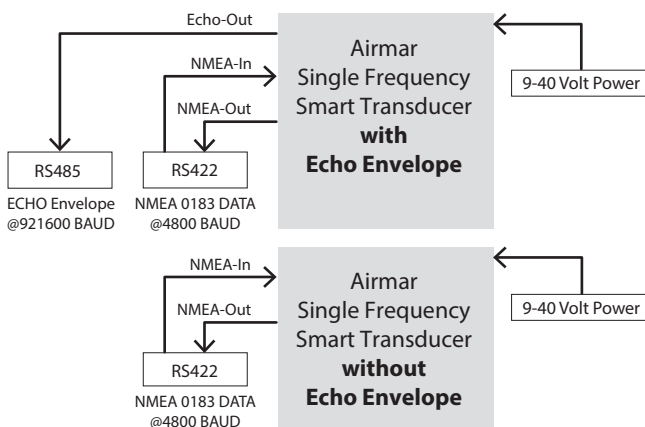

ACCURACY (Based on tank testing)			
Actual	Reported	Difference	%
3.05 m	3.07 m	+0.02 m	99.33%
4.57 m	4.59 m	+0.02 m	99.56%
5.79 m	5.82 m	+0.03 m	99.48%

Note: A minimum test tank of 50 gallons is recommended as smaller tanks may induce reverberation and interfere with measurements.

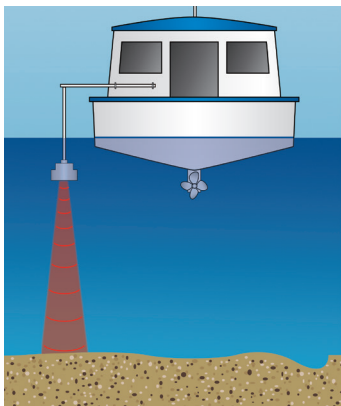

Portable surveying on any size vessel

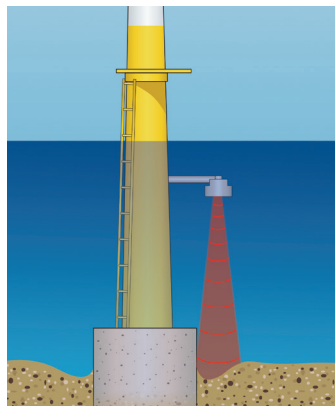

Fixed mount scour monitoring

### Mounting options:

- Portable mount for installation on survey poles
- Internal or external hull mount

### Exclusive to OEM's Only — Echo Envelope Developer Option

In addition to the bi-directional NMEA 0183 interface, a secondary transmit only interface with a proprietary protocol using RS485 is available to OEMs. The user can obtain detailed echo envelope data which may be displayed as an analog waveform.

The echo envelope is a 900-point time-series of the echo amplitude. By analyzing the shape of the echo envelope, information indicative of the seafloor type is revealed.

SPECIFICATIONS	
<b>NMEA 0183* Standard Output Sentences</b>	
Power output from transmitter:	100 W
Reverse polarity protection:	Yes
Power supply voltage:	9 – 40 VDC, Regulated
Average current draw:	300 mA @ 12 V for 30/200 kHz 150 mA @ 12 V for 200 kHz
NMEA 0183 Baud Rate:	4800 (Default)
Full Auto mode data output rate:	From 0.1 to 25 sec/interval
Manual mode:	Output rate equal to ping rate
Flash reprogrammability:	Using boot loader with encryption
Operating temperature range:	-5C to +60C
Storage temperature range:	-30C to +70C
CE certification:	Marine standard IEC60945
Minimum depth reading:	0.4 m, limited in manual mode
Maximum depth reading:	200 m, limited in manual mode
Depth display resolution:	1 cm
Depth accuracy:	99.46% at full range (see accuracy table for more info)
Submersible:	to 10 m
Housing type offered:	M195: 30/200 kHz SS510: 200 kHz
Temperature Sensor:	10k ohm +/-0.05C accuracy
Temperature resolution:	0.1C
Power and data cable:	<b>ER SS510:</b> C304, 4 twisted pairs with TPR jacket <b>ER+ M195:</b> C314, 5 twisted shielded pairs with extreme grade urethane jacket <b>ER+ SS510:</b> C316, 4 twisted shielded pairs with extreme grade urethane jacket
Maximum cable length:	20 m
Connector:	None
Sounding rate:	In full auto mode, sounding rate is variable with depth, in manual mode, sounding rate is configurable up to 10 times per second. Data output rate and ping rate are the same in manual mode, one ping produces one depth output. In full auto mode, data output rate is configurable (0.1 to 25 seconds per interval)

\*NMEA 0183 is a serial data bus standard communications protocol that permits different types of electronic equipment to communicate. For more information visit [www.nmea.org](http://www.nmea.org).

**Contact [navsurvey@airmar.com](mailto:navsurvey@airmar.com) for more information.**

**To request EchoRange™ Application Notes (3 pages),  
email with 'EchoRange™ App Notes' in the subject line.**



[www.airmar.com](http://www.airmar.com)

©2020 Airmar Technology Corporation

EchoRange\_rG 8/24/20

As Airmar constantly improves its products, all specifications are subject to change without notice. All Airmar products are designed to provide high levels of accuracy and reliability, however they should only be used as aids to navigation and not as a replacement for traditional navigation aids and techniques. EchoRange™ and Smart™ Sensors is a trademark of Airmar Technology Corporation. Other company or product names mentioned in this document may be trademarks or registered trademarks of their respective companies, which are not affiliated with Airmar.

